

**PFC SERIES MODELS**

**VENTLESS/HOODLESS COUNTERTOP DEEP FRYER**

# Advanced by Design



- SELF VENTING
- ODORLESS
- HEPA STYLE AIR FILTRATION
- INTEGRAL FIRE SUPPRESSION
- PROGRAMMABLE CONTROLS
- EASY TO CLEAN
- SMALL FOOTPRINT
- LARGE OUTPUT
- MODULAR DESIGN



**PHONE:** 403-255-7712

**TOLL FREE:** 800-265-7711

**ADDRESS:** 9298 Horton Road S.W., Calgary, AB, Canada T2V 2X4

**FAX:** 403-255-1725

**E-MAIL:** profits@perfectfry.com

**WEB:** www.perfectfry.com



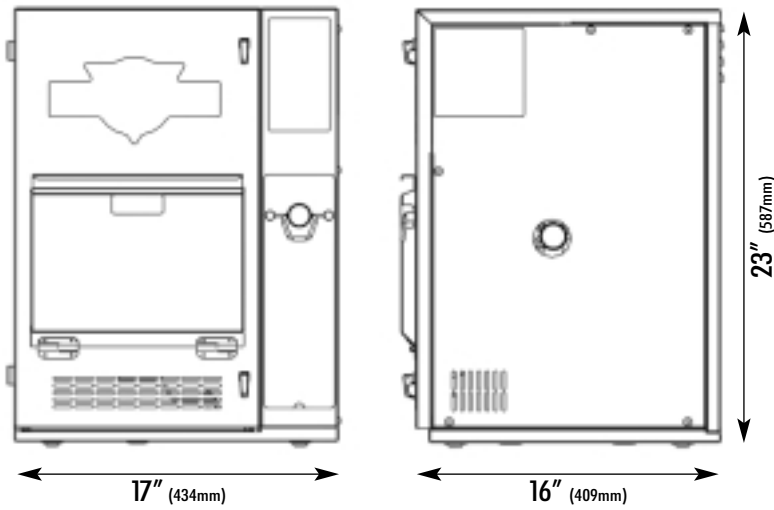

### CLEARANCES

1" all around and 0" on top.

### AIRFLOW DIAGRAM

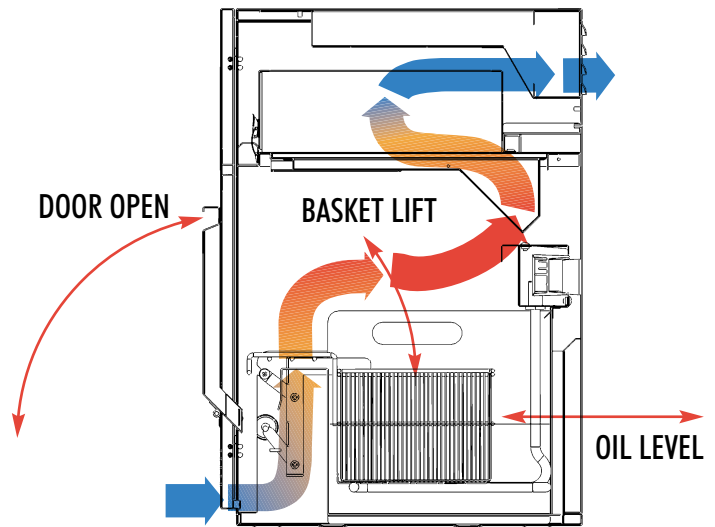

### SPECIFICATIONS TABLE

MODEL	PFC1875	PFC3750	PFC5700	PFC5708
POWER SUPPLY (volts)	120	240	240	208
CURRENT (amps)	16	16	24	27
CIRCUIT CURRENT (amps)	20	20	30	minimum 30**
NEMA NUMBER	5-20	6-20	L6-30	No Cord
POWER (kilowatts)	1.9	3.8	5.7	5.7
CAPACITY (lbs/hr)*	30	45	60	60
BASKETS (included)	1 large	1 large	1 extra large	1 extra large

### GENERAL SPECIFICATIONS (all models)

- Phase: Single (3 wire)
- Cycles: 50/60 Hz
- Weight: 80 lb (36 kg)
- Shipping Weight: 95 lb (43 kg)
- Shipping Dimensions: Depth 22" (559 mm)  
Width 22" (559 mm)  
Height 27" (686 mm)
- Shipping Cube: 7.56 ft<sup>3</sup> (.214 m<sup>3</sup>)
- Oil Capacity: 2 US Gallons (8 liters)
- Construction: 304 Stainless Steel

International models available upon request.

\*Based on up to 1 1/2 minute fast fries.

\*\*For use on an individual branch circuit rated 30 amps minimum. Power cord and plug to be installed on site by a qualified electrician.

### BASKETS

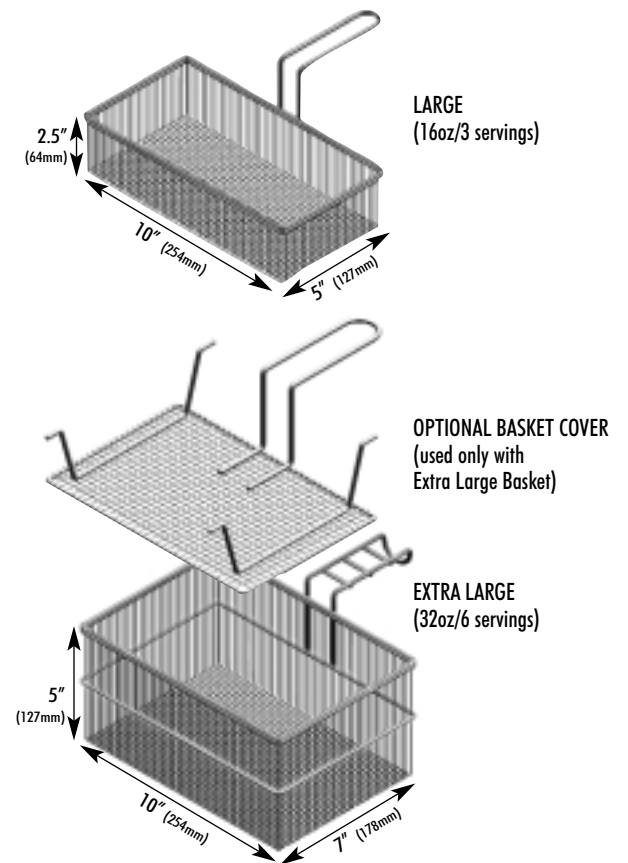

### RECEPTACLE CONFIGURATIONS

